

1.Introduction

HK422, unipolar Hall effect switch, designed with Bipolar technology, is south sensitive unipolar Hall Effective switch and includes on-chip Hall element voltage generator, a voltage regulator for operation with supply voltages of 3.5 to 40V, temperature compensation circuitry, small-signal amplifier, Schmitt trigger and an open-collector output.

The sensor is designed to respond to South poles. While the magnetic flux density(B) is larger than operate point Bop, the output will be turned on with low output level. Then the output is held until the magnetic flux (B) is lower than release point Brp. The output will be turned off with high output level.

AH422 offers a variety of packages, including TO-92, SOT-23. All packages are RoHS compliant.

2.Features

- Miniature construction
- High sensitivity of 30/20Gauss (typ.)
- Wide voltage range of 3.5 Vdc to 40 Vdc
- Temperature range of -40 °C to 125 °C
- Highest ESD performance up to ±4 kV
- Open Collector Output

3.Applications

- BLDC Motor Commutation
- Flow sensor
- Position sensor
- Speed sensor
- Proximity sensor

4.Package



5. Ordering information

Part number	Package	Packing	Ambient, T _A
HK422UA	TO92S	Bulk, 1000 pieces/bag	-40°C to 125°C
HK422SU	SOT23	Tape&Reel, 3000 pieces/reel	-40°C to 125°C

6. Pin assignment

Pin number	Name	Function
1	VDD	Power supply
2	GND	Ground
3	Vout	Output

7. Absolute Maximum Ratings

The absolute maximum value is the limiting value when the chip is applied, above which the chip can be damaged. Although the function of the chip is not necessarily damaged when the absolute maximum value is exceeded, the reliability of the chip may be affected if the absolute maximum value is exceeded for a certain time.

Parameter	Symbol	Value	Units
Supply voltage	VDD	60	V
Reverse voltage	VDD	-0.3	V
Output Sink Current	I _{sink}	40	mA
Output Voltage	Vout	60	V
Operating temperature range	T _a	-40~125	°C
Storage temperature range	T _s	-40~165	°C

8. Electrical and magnetic characteristics (Ta=25° C, VDD =5.0V)

Parameter	Symbol	Test Conditions	Min	Typ	Max	Units
Electrical characteristics						
VDD	Operating voltage		3.5		40	V
IDD	Supply current			6	9	mA
Ile	Leakage current	Off condition			10	uA
Vsat	Saturation voltage output	Iout=20mA, On condition			0.4	V
Tr	Output rising time	Pullup resistor =1kohms, Load cap=20pF			1	uS
Tf	Output falling time	Pullup resistor =1kohms, Load cap=20pF			1.5	uS
Magnetic characteristics						
Bop	Operate point	Pullup resistor =1kohms, Load cap=20pF	14	30	50	Gauss
Brp	Release point	Pullup resistor =1kohms, Load cap=20pF	5	20	35	Gauss
Bhys	Hysteresys	Pullup resistor =1kohms, Load cap=20pF	6	10	20	Gauss

9. Function diagram

HK422, unipolar Hall Effect switch, designed with Bipolar technology, includes on-chip Hall element voltage generator, a voltage regulator for operation with supply voltages of 3.5 to 60V, temperature compensation circuitry, small-signal amplifier, Schmitt trigger and an open-collector output.

High Sensitive Digital-Unipolar Hall Effect Sensor

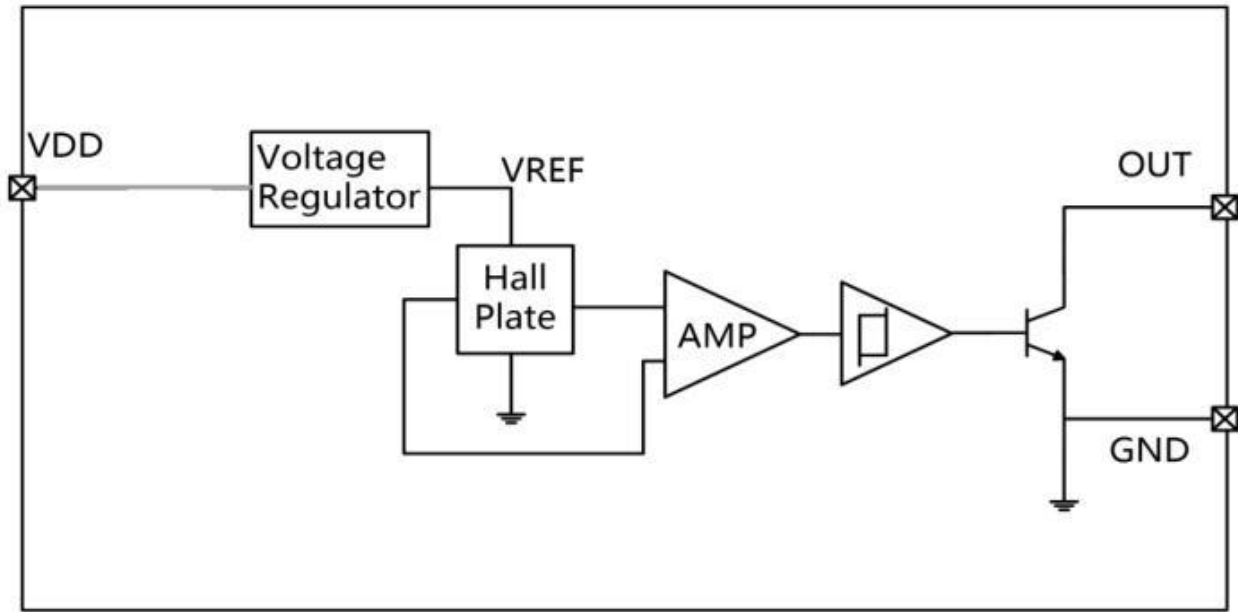

10.Pin orientation

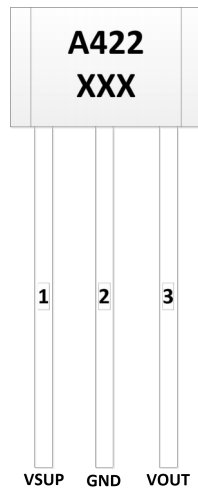

TO92S

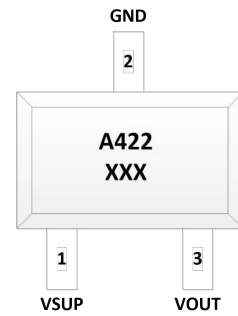

SOT23

High Sensitive Digital-Unipolar Hall Effect Sensor

Application example: $V_{DD} = 5V$

A positive magnetic field is defined as a South pole near the marked side of the package.

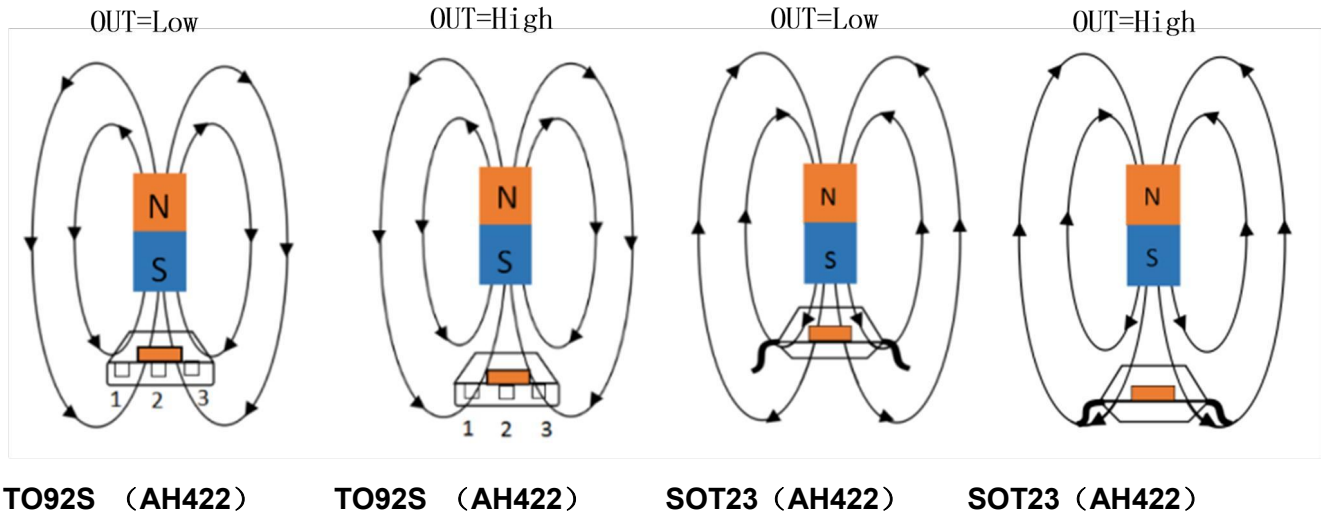

Output Behavior

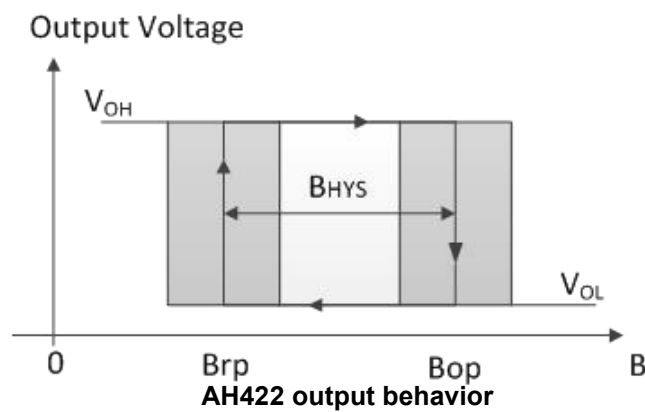

High Sensitive Digital-Unipolar Hall Effect Sensor

11. Temperature characteristic

HK422 At Vcc=5V, Magnetic characteristics vs. Temperature.

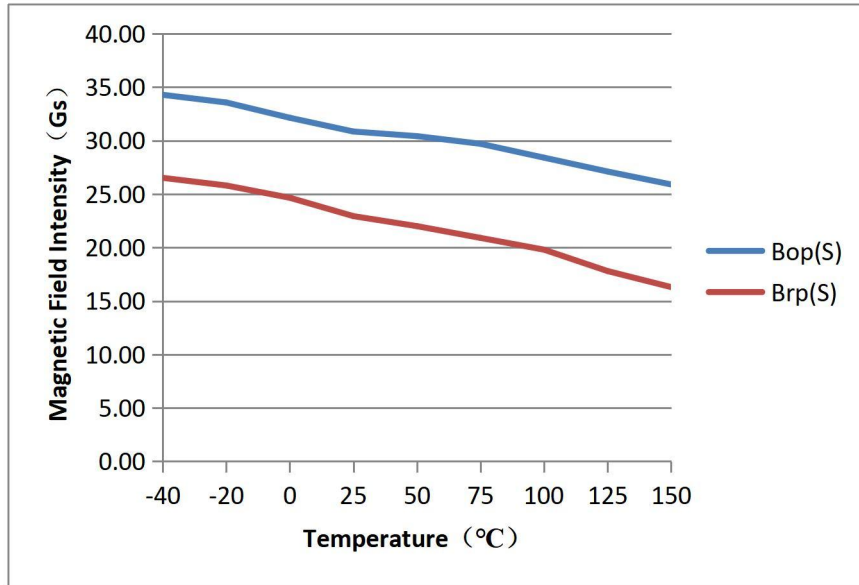

HK422 At Vcc=5V, Supply Current vs. Temperature.

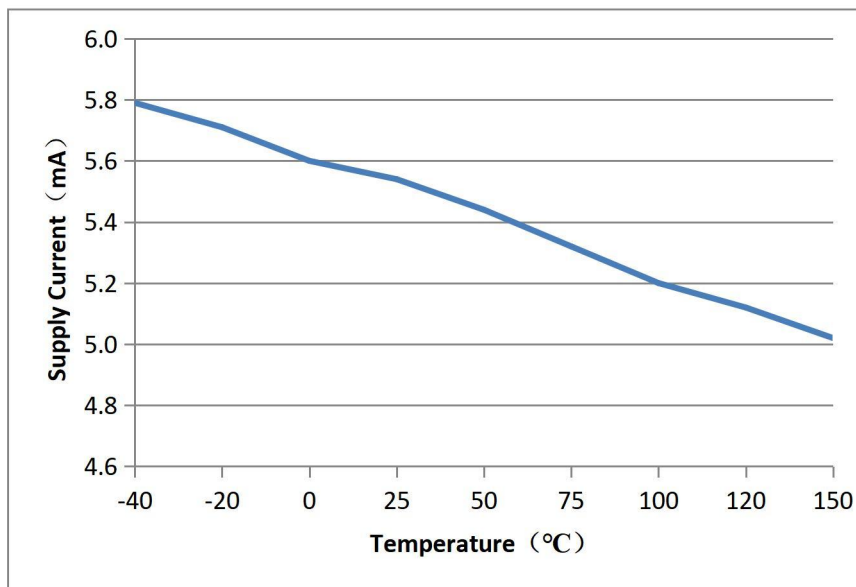

12. Application Circuits

Typical application circuit (see the following circuit) $R_L = 4700$ ohms

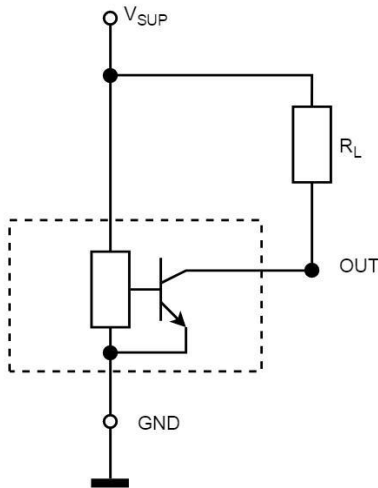

Case 1 of typical application circuit

Automotive and Harsh, Noisy Environments Three-Wire Circuit is show below. Here, $R_V = 100$ ohms, $C_P = 4.7$ nF, and $C_L = 1$ nF.

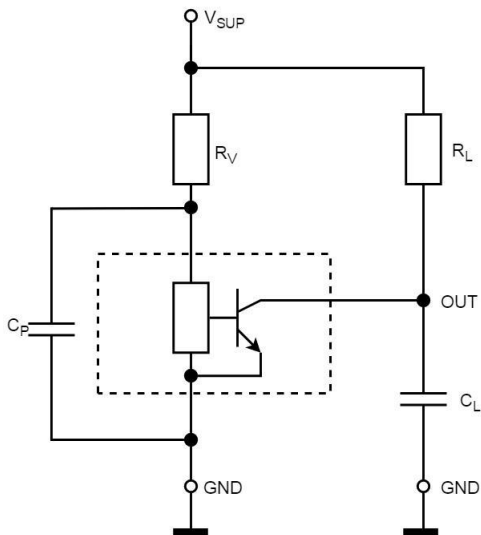

Case 2 of typical application circuit

High Sensitive Digital-Unipolar Hall Effect Sensor

13.Package dimensions

T092S

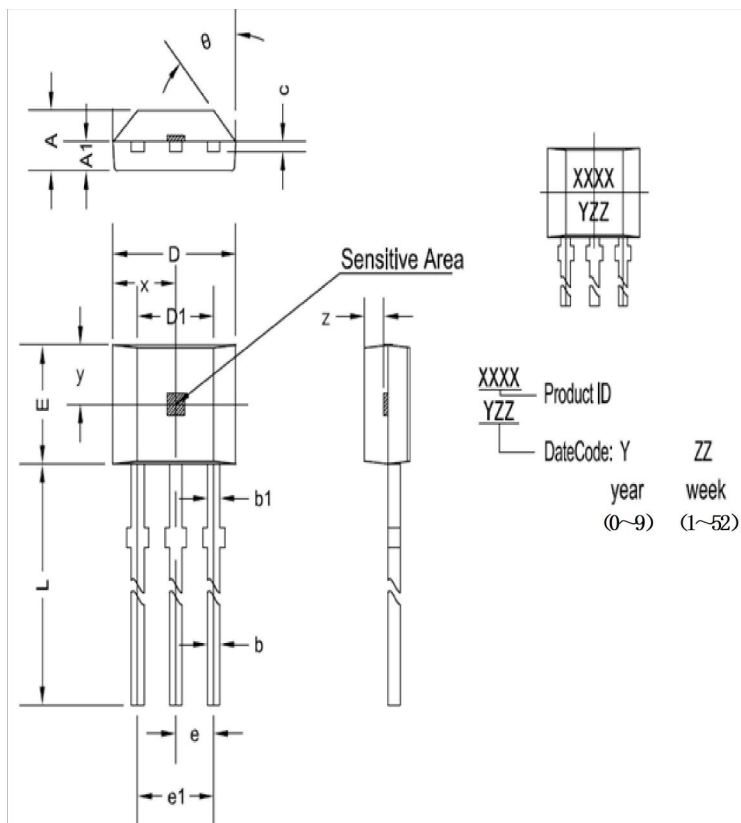

T092S dimensions

symbol	Size (mm)		Size (in inches)	
	minimum	maximum	minimum	maximum
A	1.42	1.67	0.056	0.066
A1	0.66	0.86	0.026	0.034
b	0.35	0.56	0.014	0.022
b1	0.4	0.55	0.016	0.022
C	0.36	0.51	0.014	0.02
D	3.9	4.2	0.154	0.165
D1	2.97	3.27	0.117	0.129
E	2.9	3.28	0.114	0.129
e	1.270 TYP		0.050 TYP	
e1	2.44	2.64	0.096	0.104
L	13.5	15.5	0.531	0.61
x	2.025TYP		0.080TYP	
y	1.545TYP		0.061TYP	
z	0.500TYP		0.020TYP	
θ	45°TYP		45°TYP	

High Sensitive Digital-Unipolar Hall Effect Sensor

SOT23

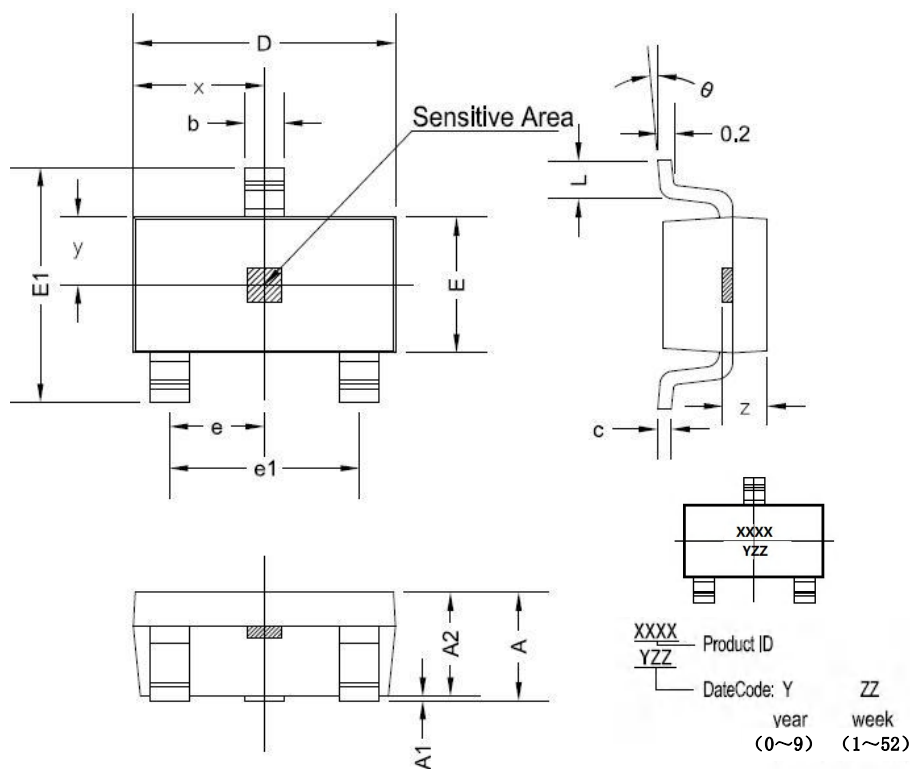

SOT23 dimensions

symbol	Size (mm)		Size (in inches)	
	minimum	maximum	minimum	maximum
A	1.05	1.25	0.041	0.049
A1	0	0.1	0	0.004
A2	1.05	1.15	0.041	0.045
b	0.3	0.5	0.012	0.02
c	0.100	0.2	0.004	0.008
D	2.82	3.02	0.111	0.119
E	1.5	1.7	0.059	0.067
E1	2.65	2.95	0.104	0.116
e	0.950 TYP		0.037 TYP	
e1	1.8	2	0.071	0.079
L	0.3	0.6	0.012	0.024
x	1.460TYP		0.057TYP	
y	0.800TYP		0.032TYP	
z	0.600TYP		0.024TYP	
θ	0°	8°	0°	8°

